



ORDERING CODE

HLS-102F - DC12V

NOMINAL VOLTAGE
DC5V,DC12V,DC24V

TYPE

CONTACT DATA

Contact Form	1A
Contact Material	Ag Alloy
Contact Ratings	20A 250VAC/30VDC
Max Switching Voltage	250VAC 30VDC
Max Switching Current	20A
Max Switching Power	5000VAC 600W
Initial Contact Resistance	50m Ω Max at 6VDC 1A
Life Expectancy Electrical	100,000 Operations (rated load)
Life Expectancy Mechanical	2,000,000 Operations (no load)

GENERAL DATA

Insulation Resistance	1000M Ω min at 500VDC
Dielectric Strength Between Open Contacts	1000VAC 50-60HZ (1 minute)
Dielectric Strength Between Contacts And Coil	4500VAC 50-60HZ (1 minute)
Operate Time	20ms max
Release Time	10ms max
Ambient Temperature	-25°C to +55°C
Shock Resistance	10G
Vibration Resistance	10-55Hz, 1.5mm double amplitude
Ambient humidity	40-85% RH
Weight	Approx 23g
Safety Standard	CQC

COIL DATA

Rated Voltage (VDC)	Coil Resistance Ω (± 10%)	Max Operate Voltage (VDC)	Min Release Voltage (VDC)	Max Applied Voltage (VDC)
	0.9W			
5	27.5	3.75	0.25	6.5
12	160	9	0.6	15.6
24	640	18	1.2	31.2

Outline Dimension (mm)

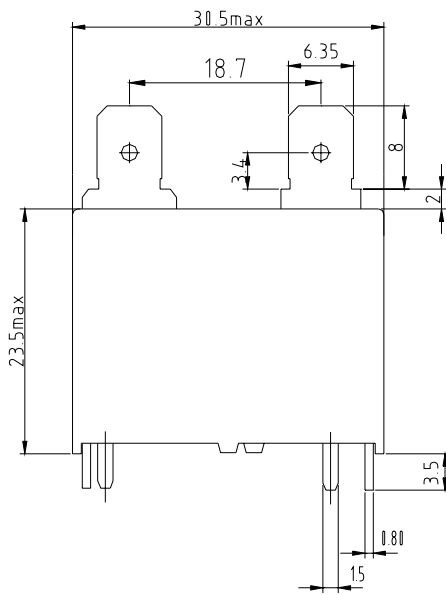

PC Board layout

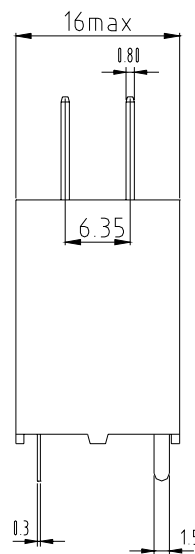

Wiring Diagram

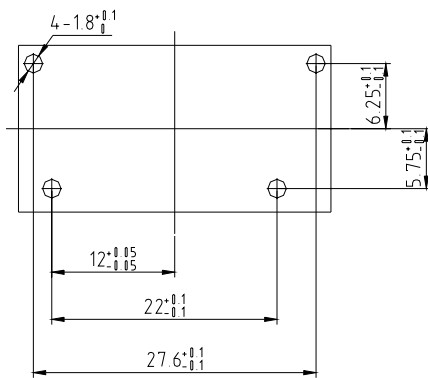

(Bottom View)

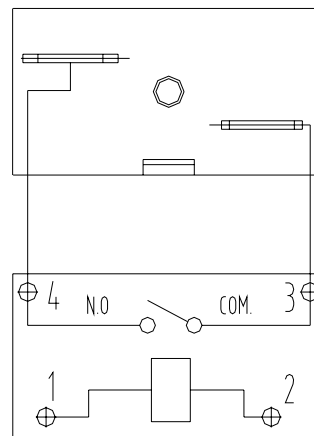

(Top View)

(Bottom View)