

»» Features

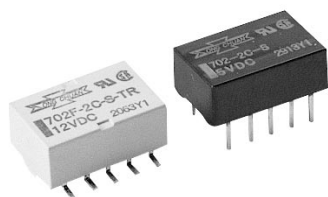

- Compact size and low 5mm profile.
- Low power consumption (140mW for single-side stable, 100 to 300mW for latching type).
- Low thermo electromotive force.
- Low magnetic interference enables high-density mounting.
- Single-and double-winding latching types also available.
- UL and CSA approval.

»» Type List

Terminal style	Contact form	Relay function	Terminal shape	Enclosure style
				Plastics sealed
PCB terminal	2C (DPDT)	Single-side stable	PCB terminal	702-2C-S
		Single-winding latching		702U-2C-S
		Double-winding latching		702K-2C-S
	Single-side stable	Surface mount terminal	702F-2C-S-TR	

»» Ordering Information

702 U F - 2C - S - TR
1 2 3 4 5 6

- | | |
|---|---|
| <p>1. 702 -- Basic series designation</p> <p>2. Blank -- Single-side stable
U -- Single-winding latching
K -- Double-winding latching</p> <p>3. Blank -- PCB terminal
F -- Surface mount terminal</p> | <p>4. 2C -- Double pole double throw</p> <p>5. S -- Plastics sealed
U -- Ultrasonically cleanable</p> <p>6. Blank -- Standard type
TR -- Tape packing</p> |
|---|---|

»» Contact Rating

Rated load (resistive load)	0.5A at 125VAC, 1A at 30VDC
Contact material	Ag + Au-clad
Max. continuous current	1A
Maximum switching voltage	125VAC, 110VDC
Maximum switching capacity	62.5VA, 33W
Min. permissible load	0.01 μ A at 10mVDC

Note : P level: $\lambda_{60} = 0.1 \times 10^{-6}$ / operation

702

»» Coil Rating (DC)

◆ Single-side stable

Rated voltage (V)	Rated current $\pm 10\%$ at 23 °C (mA)	Coil resistance $\pm 10\%$ at 23 °C (Ω)	Max. continuous voltage at 23 °C	Pick up voltage(Max) at 23 °C	Drop out voltage(Min) at 23 °C	Power consumption at rated voltage
3	46.7	64.3	200 % of rated voltage	75 % of rated voltage	10 % of rated voltage	approx. 0.14W
5	28.1	178				
6	23.3	257				
9	15.5	579				
12	11.7	1028	170 % of rated voltage			approx. 0.2W
24	8.3	2880				

◆ Single-winding latching

Rated voltage (V)	Rated current $\pm 10\%$ at 23 °C (mA)	Coil resistance $\pm 10\%$ at 23 °C (Ω)	Max. continuous voltage at 23 °C	Pick up voltage(Max) at 23 °C	Drop out voltage(Min) at 23 °C	Power consumption at rated voltage
3	33.3	90	180 % of rated voltage	75 % of rated voltage	75 % of rated voltage	approx. 0.1W
5	20	250				
6	16.7	360				
9	11.1	810				
12	8.3	1440				
24	6.25	3840				approx. 0.15W

◆ Double-winding latching

Rated voltage (V)	Rated current $\pm 10\%$ at 23 °C (mA)	Coil resistance $\pm 10\%$ at 23 °C (Ω)	Max. continuous voltage at 23 °C	Pick up voltage(Max) at 23 °C	Drop out voltage(Min) at 23 °C	Power consumption at rated voltage
3	66.7	45	160 % of rated voltage	75 % of rated voltage	75 % of rated voltage	approx. 0.2W
5	40	125				
6	33.3	180				
9	22.2	405				
12	16.7	720	130 % of rated voltage			approx. 0.3W
24	12.5	1920				

»» Specification

Contact resistance ⁽¹⁾	100 mΩ Max.	
Operate time ⁽¹⁾	single-side stable type	: 3 ms Max.
	latching type	: 3 ms Max.
Release time ⁽¹⁾	single-side stable type	: 2 ms Max.
	latching type	: 3 ms Max.
Bounce time	operate	: approx 0.5ms
	release	: approx 0.5ms
	set/reset	: approx 0.5ms
Min. set/reset signal width	latching type : 5 ms min.	
Insulation resistance ⁽¹⁾	1000 MΩ Min. (DC 500V)	
	Between set and reset coil : 100 MΩ (DC 125V)	
Dielectric strength ⁽¹⁾	Between coil and contacts	: AC 1000V, 50/60Hz 1 min.
	Between contact of different polarity	: AC 1000V, 50/60Hz 1 min.
	Between contact of same polarity	: AC 750V, 50/60Hz 1 min.
	Between set and reset coil :	AC 125V, 50/60Hz 1 min. (double-winding latching)
Surge withstand voltage	Between contact of same polarity : AC 1500V (10X160 μs) (conforms to FCC part 68)	
Vibration resistance	Operating extremes	10~55Hz , double amplitude 5 mm
	Damage limits	10~55Hz , double amplitude 3 mm
Shock resistance	Operating extremes	500 m/s ²
	Damage limits	1000 m/s ²
Life expectancy	Mechanical	100,000,000 operations (frequency 36,000 operations/hr)
	Electrical	200,000 operations (frequency 1,800 operations/hr)
Operating ambient temperature	-40 ~ +70 °C (no freezing)	
Weight	Approx. 1.5 g	

Note : (1) initial value

»» Safety Approval

Certified	UL	CSA
File No.	E74321	218083

»» Safety Approval Rating

UL	CSA
2A 30VDC	2A 30VDC
0.3A 110VDC	0.3A 110VDC
0.5A 125VAC	0.5A 125VAC

702

»»» Outline Dimensions

◆702

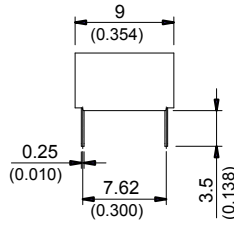
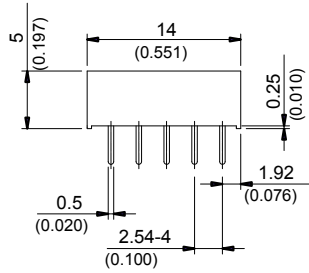

◆702F

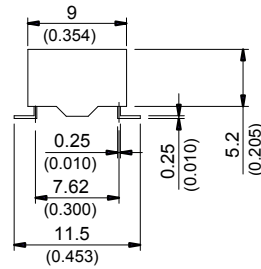
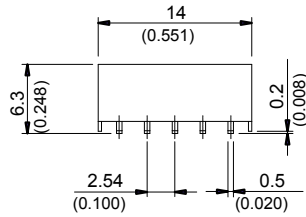

»»» Wiring Diagram BOTTOM VIEW

◆702

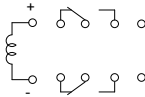

◆702U

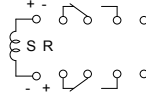

◆702K

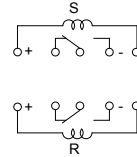

◆702F

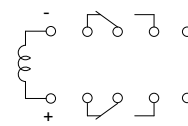

»»» PC Board Layout BOTTOM VIEW

◆702

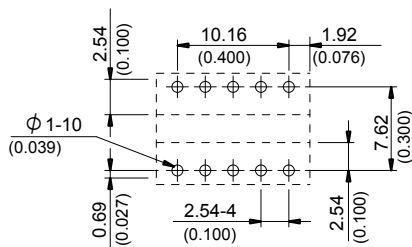

◆702F

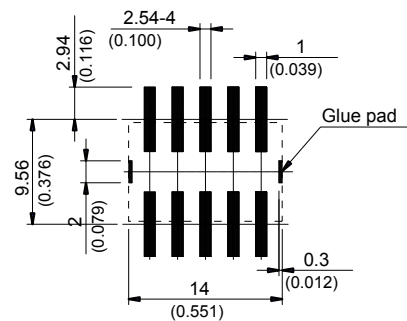

»» Engineering Data

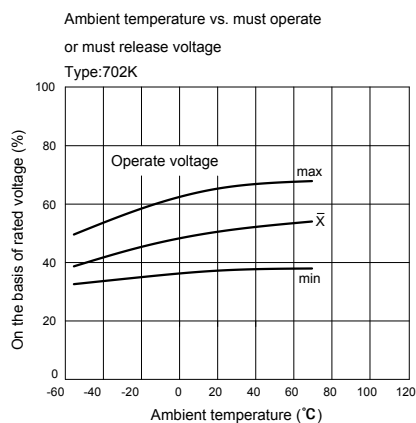
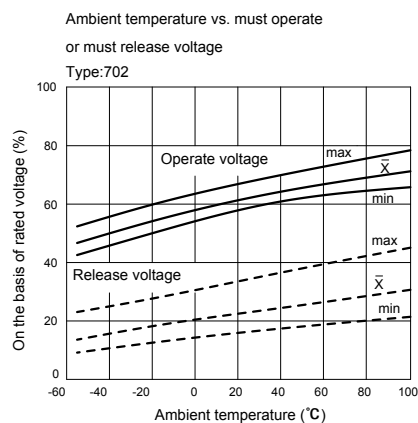
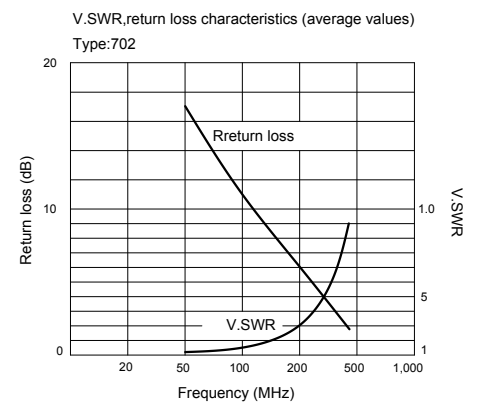
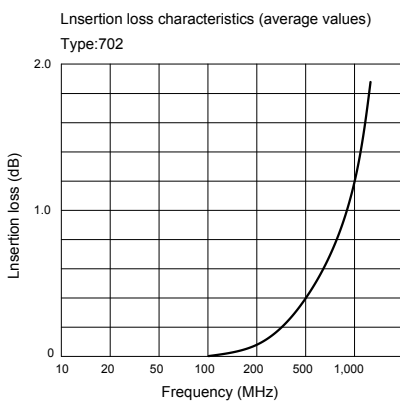
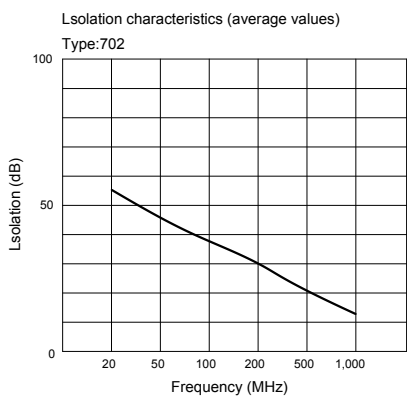
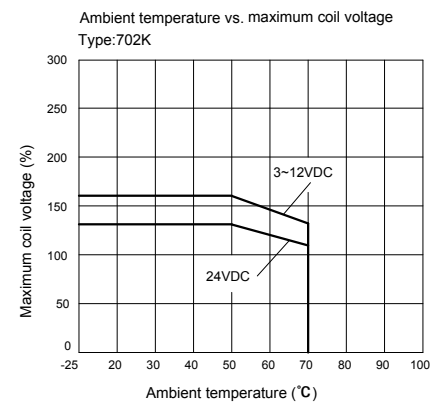
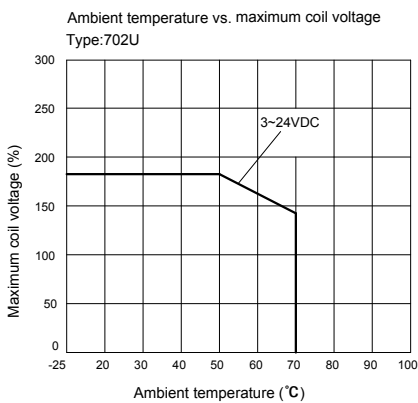
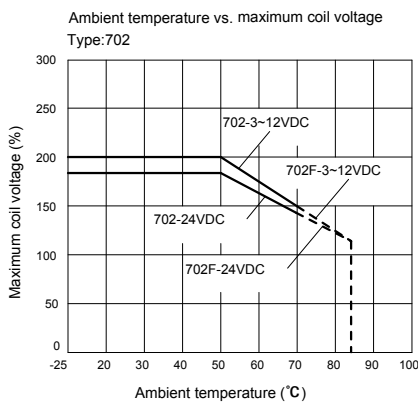
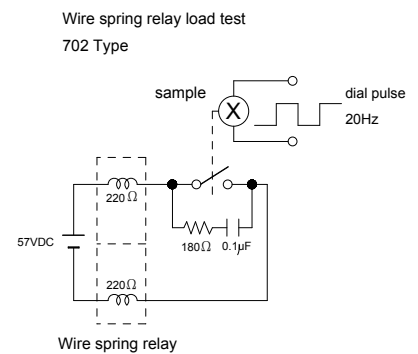
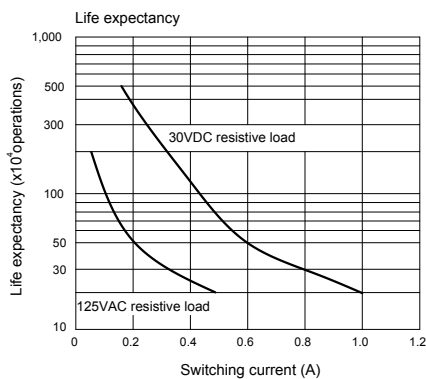
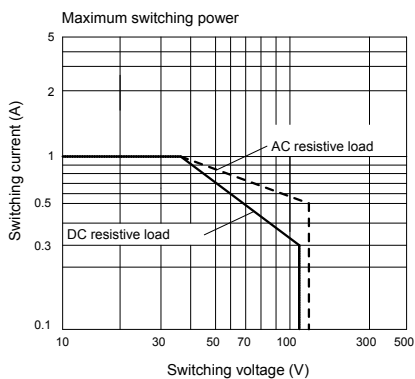

702

Shock malfunction
Type:702

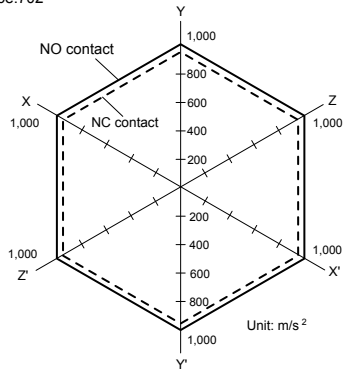

Shock direction

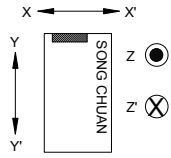

Conditions:

Shock is applied in +X, +Y, and +Z directions three times each with and without energizing the Relays to check the number of contact malfunctions.

Rating:500m/s²

Electrical life expectancy
(with must operate and must release voltage)
Type:702

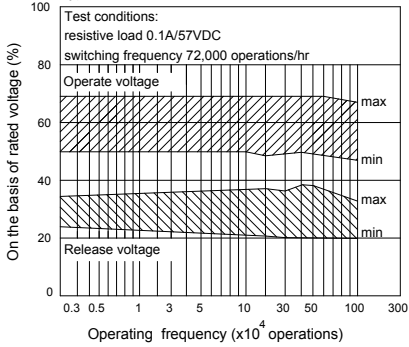

Electrical life expectancy
(contact resistance)
Type:702

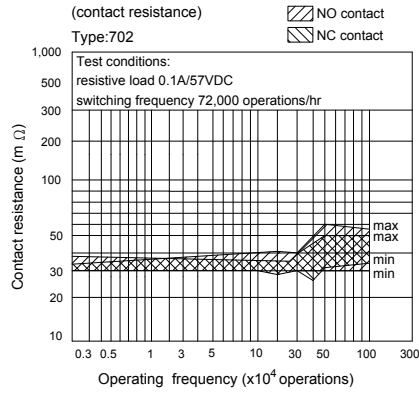

Contact reliability test
Type:702

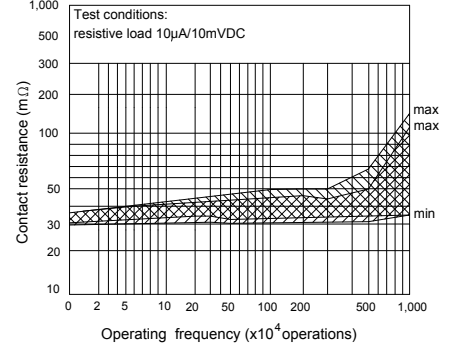

External magnetic Interference (average value)
Type:702K

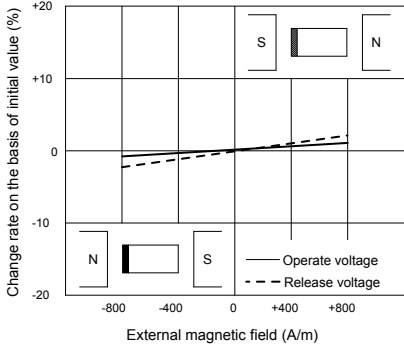

External magnetic Interference (average value)
Type:702K

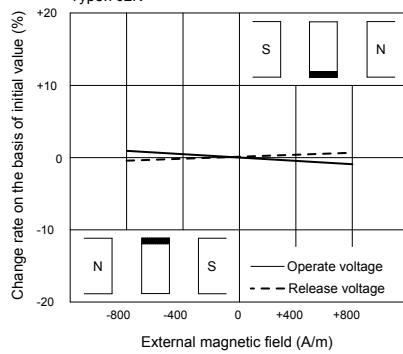

External magnetic Interference (average value)
Type:702K

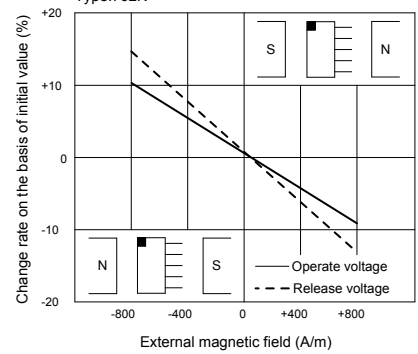

Must operate and must release time distribution
Type:702

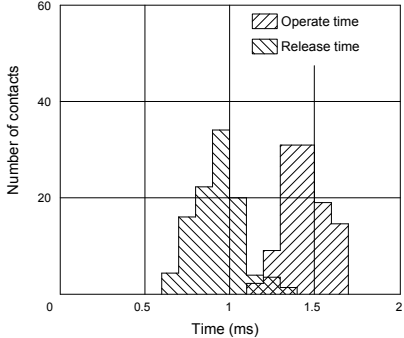

Must operate and must release bounce time distribution
Type:702

