

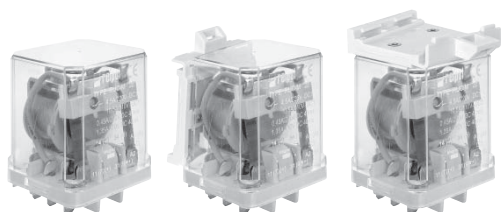



RUC-M



with adaptor (V)

with adaptor (H)

• **Magnetic blow-out relays for high DC load with the contact plate with permanent magnet whose magnetic field blows out the electric arc between the contacts** • AC and DC coils • Mounting: in sockets; 35 mm rail mount acc. to PN-EN 60715; on panel; PCB • Version: faston 187 (4,8 x 0,5 mm) • Contact gap: 3 mm (version 2 NO); 6 mm (version 1 NO) • Additional features: L - light indicator (LED) • Applications: control of electromagnets; systems of heating, cooling, ventilation, air conditioning; control with single-phase and three-phase motors; catering industry machines and equipment; automation systems; etc. • Recognitions, certifications, directives: RoHS,   

Contact data

Number and type of contacts	1 NO (double-break)	2 NO
Contact material	AgCdO	
Rated / max. switching voltage	250 V DC, AC / 350 V DC; 440 V AC ❶	
Min. switching voltage	10 V	
Rated load (capacity)	DC1	16 A / 24 V DC; 14 A / 110 V DC 12 A / 220 V DC
	DC L/R=40 ms	16 A / 24 V DC; 5,4 A / 110 V DC 3 A / 220 V DC
	AC1	16 A / 250 V AC
Min. switching current	10 mA	
Max. inrush current	40 A 20 ms	
Rated current	16 A	
Min. breaking capacity	1 W	
Contact resistance	≤ 100 mΩ	
Max. operating frequency	AC1	• at rated load • no load
		1 200 cycles/hour 12 000 cycles/hour

Coil data

Rated voltage	AC	12 ... 240 V 50/60 Hz	
	DC	12 ... 220 V	
Must release voltage	AC: ≥ 0,15 U _n	DC: ≥ 0,1 U _n	
Operating range of supply voltage	AC: 0,85...1,1 U _n	DC: 0,8...1,1 U _n	see Tables 1, 2
Rated power consumption	AC	2,8 VA	
	DC	1,7 W	

Insulation according to PN-EN 60664-1

Insulation rated voltage	400 V AC		
Rated surge voltage	4 000 V 1,2 / 50 μs		
Overvoltage category	III		
Insulation pollution degree	3		
Dielectric strength	• between coil and contacts	2 500 V AC	type of insulation: reinforced
	• contact clearance	4 000 V AC	type of clearance: full-disconnection
	• pole - pole	2 500 V AC	contacts 2 NO, type of insulation: basic
Contact - coil distance	• clearance	≥ 6,3 mm	
	• creepage	≥ 8 mm	

General data

Operating / release time (typical values)	20 ms / 15 ms	
Electrical life	• resistive DC1	≥ 2 x 10 ⁵ 12 A, 220 V DC
	• DC L/R=40 ms	≥ 2 x 10 ⁵ 3 A, 220 V DC
		≥ 2 x 10 ⁵ 4,5 A, 220 V DC ≥ 2 x 10 ⁵ 0,45 A, 220 V DC
Mechanical life (cycles)	≥ 2 x 10 ⁷	
Dimensions (L x W x H)	36,1 x 38,6 x 45,5 mm ❷	
Weight	80 g ❸	85 g ❹
Ambient temperature	• storage	-40...+85 °C
	• operating	-40...+70 °C
Cover protection category	IP 00	PN-EN 60529
Shock resistance	10 g	
Vibration resistance	5 g 10...150 Hz	
Solder bath temperature	max. 270 °C	
Soldering time	max. 5 s	

The data in bold type pertain to the standard versions of the relays.

❶ For RUC-M with GUC11 socket, max. switching voltages and coil voltages of relays are limited to 250 V AC/DC.

❷ For plug-in sockets version. For version: with (V) adaptor: 58,75 x 38,6 x 45,9 mm; with (H) adaptor: 46,8 x 38,6 x 62,45 mm.

For version with mounting flange: 66,3 x 38,6 x 36,1 mm. For PCB version: 36,1 x 38,6 x 52,5 mm.

❸ Weight of plug-in sockets version and PCB version. ❹ Weight of version with (V) or (H) adaptor, and version with mounting flange.

RUC-M

Coil data - DC voltage version, reinforced

Table 1

Coil code	Rated voltage V DC	Coil resistance ±10% at 20°C Ω	Coil operating range V DC	
			min. (at 20°C)	max. (at 55°C)
W012	12	85	9,6	13,2
W024	24	345	19,2	26,4
W048	48	1 370	38,4	52,8
W110	110	7 300	88,0	121,0
W220	220	30 000	176,0	242,0

Coil data - AC 50/60 Hz voltage version

Table 2

Coil code	Rated voltage V AC	Coil resistance ±10% at 20°C Ω	Coil operating range V AC	
			min. (at 20°C)	max. (at 55°C)
5012	12	18,5	9,6	13,2
5024	24	75,0	19,2	26,4
5115	115	1 840,0	92,0	126,5
5120	120	1 910,0	96,0	132,0
5230	230	7 080,0	184,0	253,0
5240	240	7 760,0	192,0	264,0

Connection diagrams (pin side view)

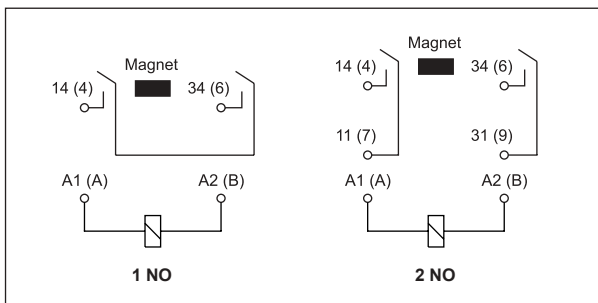

Dimensions - version with mounting flange in the wall of the cover

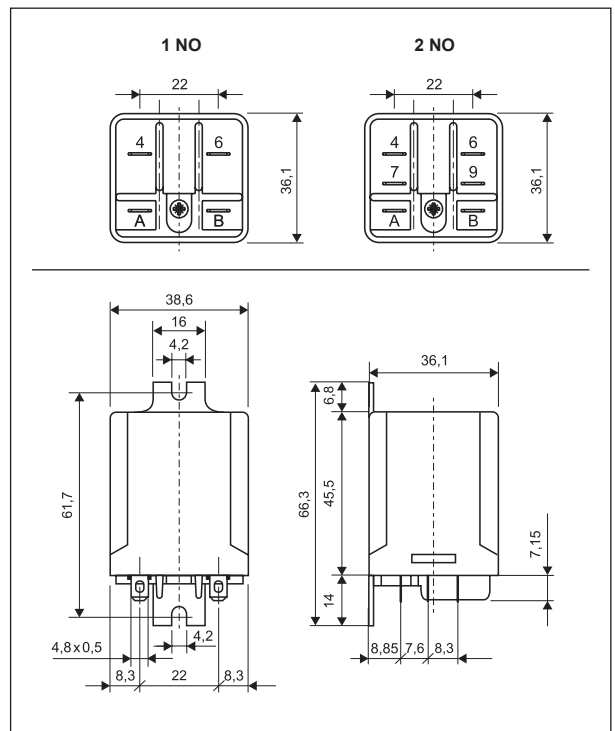

Design

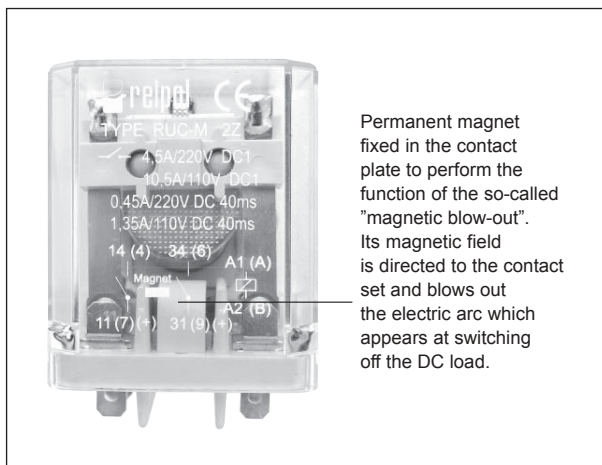

RUC-M

Dimensions - plug-in version (standard)

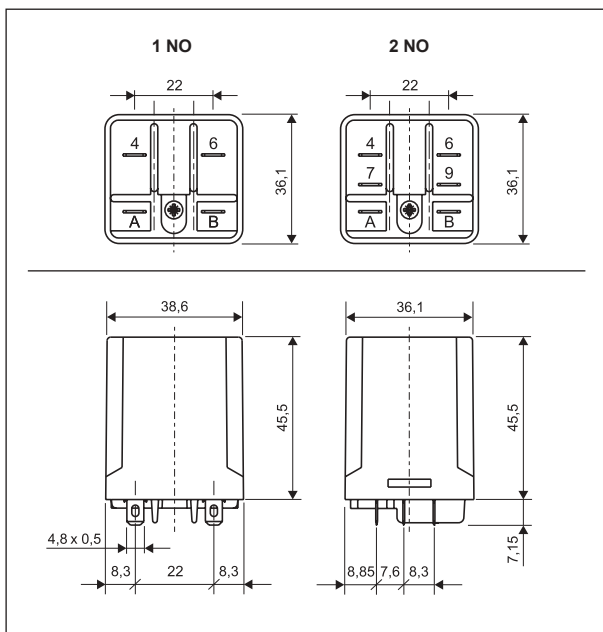

Dimensions - PCB version

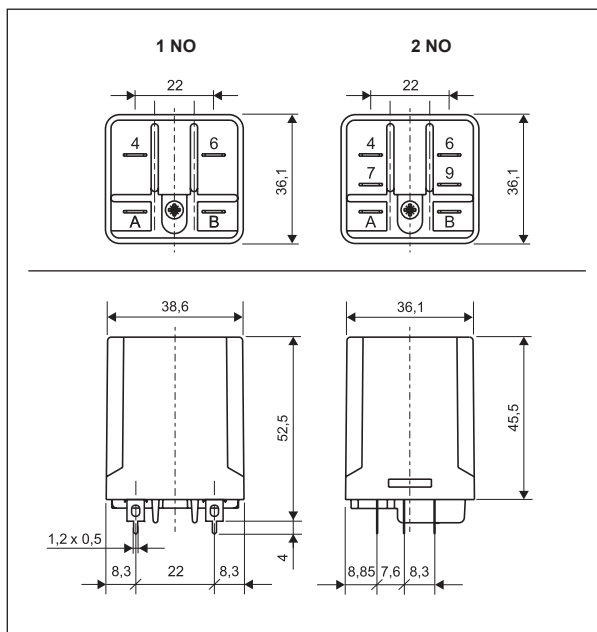

Dimensions - version with vertical adaptor (V)

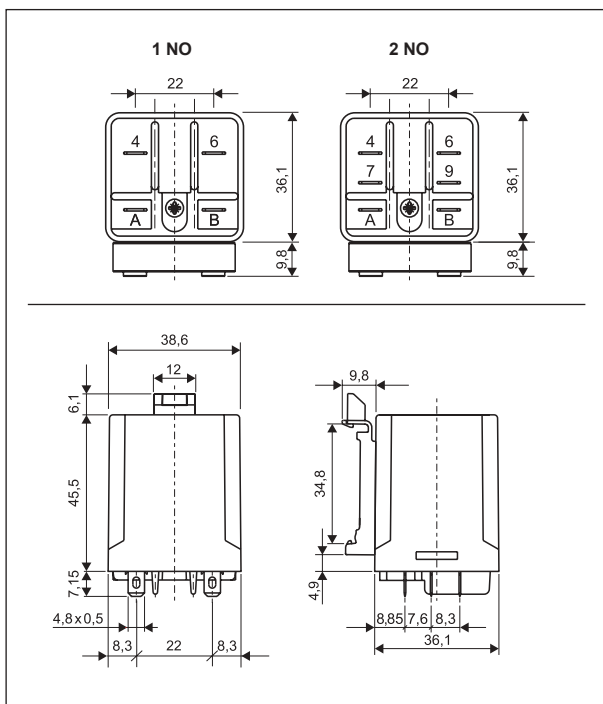

Dimensions - version with horizontal adaptor (H)

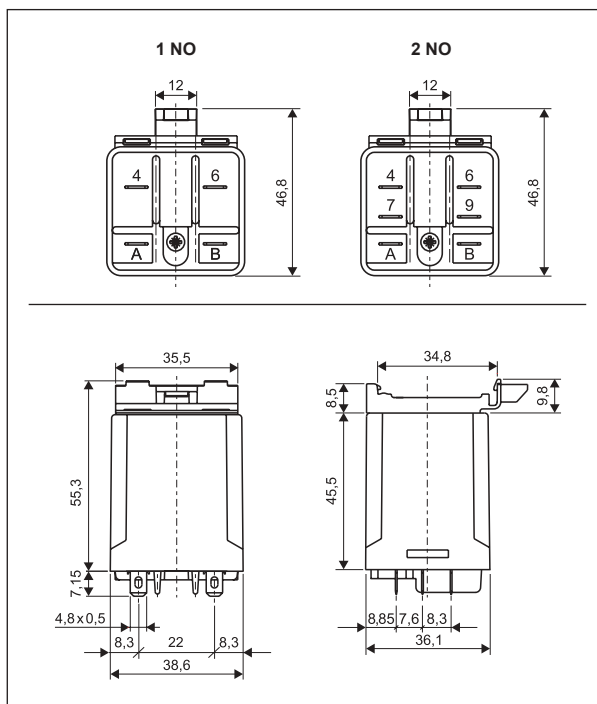

Mounting

Relays RUC-M are offered in versions: • standard, for screw terminals plug-in sockets **GUC11** with clip **MBA**, 35 mm rail mount acc. to PN-EN 60715 or on panel mounting with two M3 screws • with mounting flange in the wall of the cover, on panel mounting, flat insert connectors - faston 187 (4,8 x 0,5 mm) • with vertical (V) or horizontal (H) adaptors for direct mounting on 35 mm rail mount acc. to PN-EN 60715, flat insert connectors - faston 187 (4,8 x 0,5 mm) • for direct PCB mounting

Relays are not available with (V) or (H) adaptor, and cover with mounting flange.

For RUC-M with GUC11 socket, max. switching voltages and coil voltages of relays are limited to 250 V AC/DC.

RUC-M

Electrical life at AC resistive load.
Switching frequency: 1 200 cycles/hour

Fig. 1

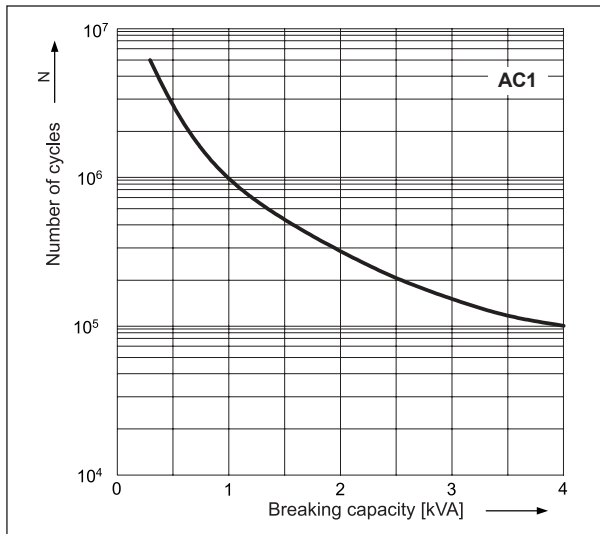

Electrical life reduction factor at AC inductive load

Fig. 2

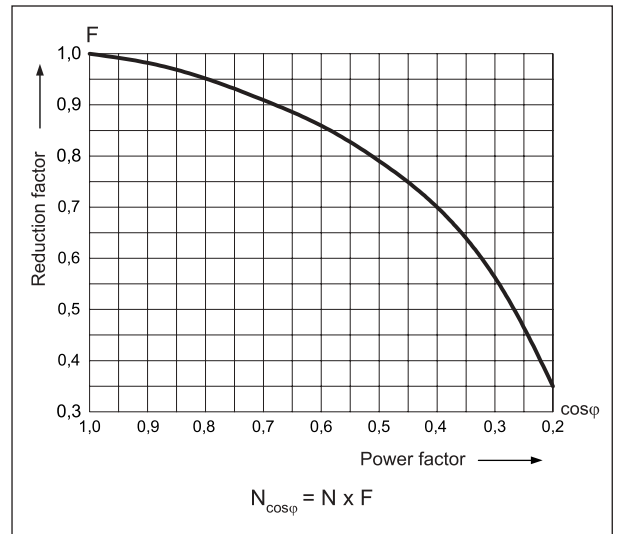

Ordering codes

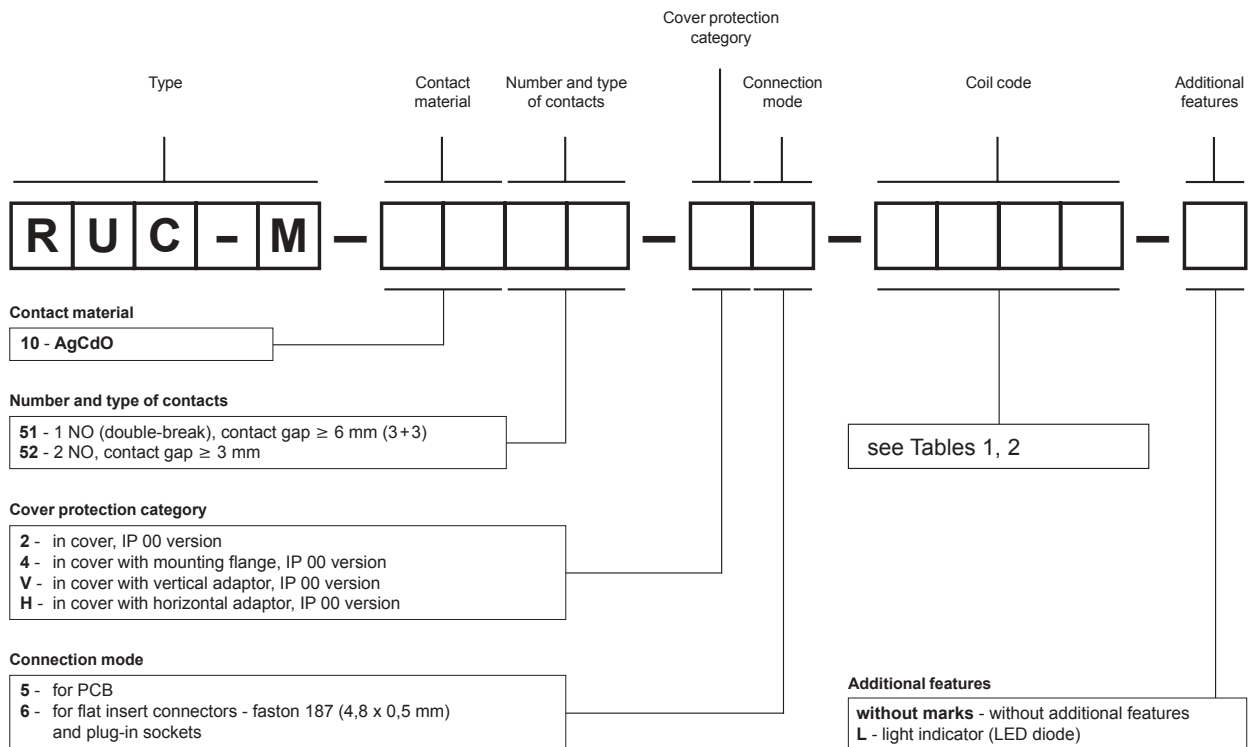

Examples of ordering codes:

- RUC-M-1051-26-W024** relay **RUC-M**, faston 187 (4,8 x 0,5 mm), contact material AgCdO, with one normally open contact (double-break), with contact gap ≥ 6 mm (3+3), in cover IP 00, for plug-in sockets GUC11, voltage version 24 V DC - reinforced coil
- RUC-M-1052-V6-5230-L** relay **RUC-M**, faston 187 (4,8 x 0,5 mm), contact material AgCdO, with two normally open contacts, with contact gap ≥ 3 mm, in cover IP 00, with vertical adaptor (V), for flat insert connectors, voltage version 230 V AC 50/60 Hz, with light indicator (LED diode)
- RUC-M-1051-25-5024** relay **RUC-M**, contact material AgCdO, with one normally open contact (double-break), with contact gap ≥ 6 mm (3+3), in cover IP 00, for PCB, voltage version 24 V AC 50/60 Hz